

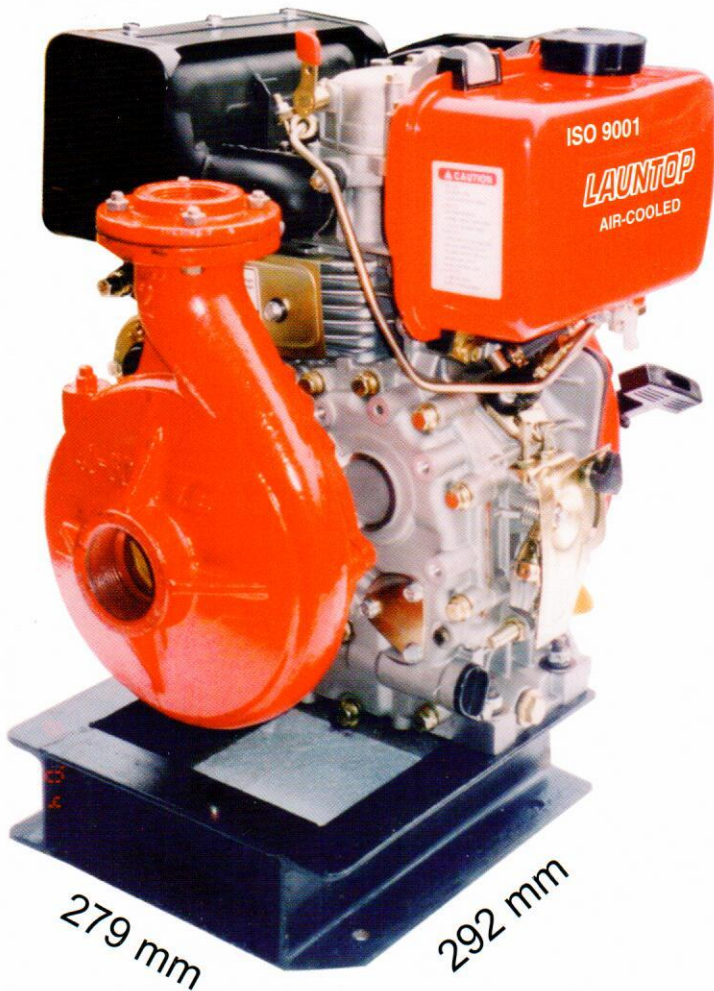

# LAUNTOP DIESEL ENGINE

# LA 178



### CHARACTERISTICS

- Four stroke diesel cycle • Direct injection • Air Cooling with flywheel fan • Gravity fuel system
- Forced lubrication • Automatic mechanical fuel supplement • Centrifugal speed governor • Automatic fuel bleeding system • Electric or manual starting
- Counterclockwise rotation (looking at power take off) • Die-cast aluminium crankcase with liner of integral cast iron • Built-in mounts.

### PUMP SPECIFICATION

- Cast Iron Casing
- Bronze Impeller
- Shaft Sleeve: Stainless Steel
- Stuffing Box: Mechanical Seal (Carbon Ceramic)
- Liquid Temperature Up To Maximum 90°

### Pump Performance Curve

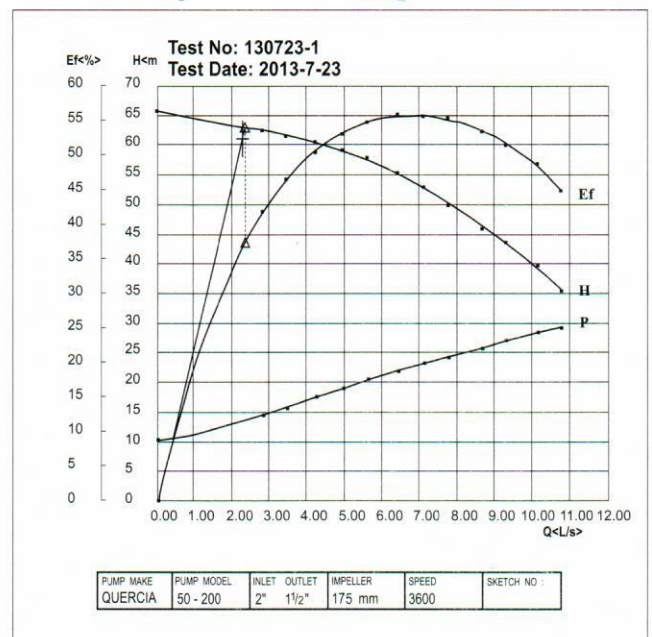

### SPECIFICATIONS:

MODEL	LA 178	
Type	Single-cylinder, Vertical, 4-stroke air-cooled diesel engine	
Combustion System	Direct Injection	
Bore x Stroke (mm)	78x62	
Displacement (cc)	296	
Engine Speed (rpm)	3000	3600
Maximum Output (hp)	5.4	6.0
Continuous Output (hp)	5.0	5.5
Power Take Off	Crankshaft or Camshaft (Camshaft PTO rpm is 1/2)	
Starting System	Recoil or Recoil/Electric	
Fuel Tank Capacity (L)	3.5	
Lube Oil Capacity (L)	1.1	
Dimensions L x W x H (mm)	383 x 421 x 450	
Dry Weight (Recoil) (kg)	34	
Dry Weight (Electric) (kg)	39	

# OVERALL DIMENSIONS AND INSTALLATION:

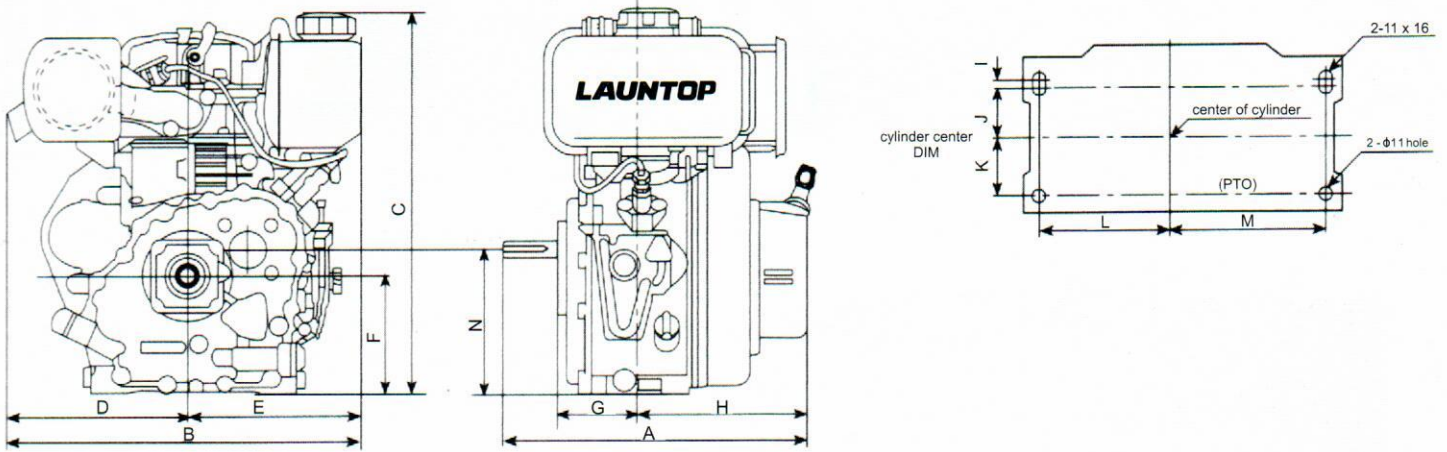

Suitable size	A	B	C	D	E	F	G	H	I	J	K	L	M	N
LA178	358	421	450	218	203	145	96	199	5	41.5	43.5	104	144	171.8

Note: (All datas are subject to change without notice)

Performance measured after 30 hours running-in, with air cleaner and exhaust silencer.

Atmospheric conditions: Barometric pressure: **760mmHg [750mmHg]**  
 ISO 3046/1  
 Intake air temperature: **20°C [27°C]** Relative humidity: **60% [60%]**

Application code:

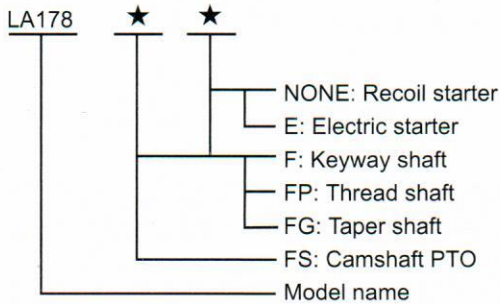

## PERFORMANCE CURVES:

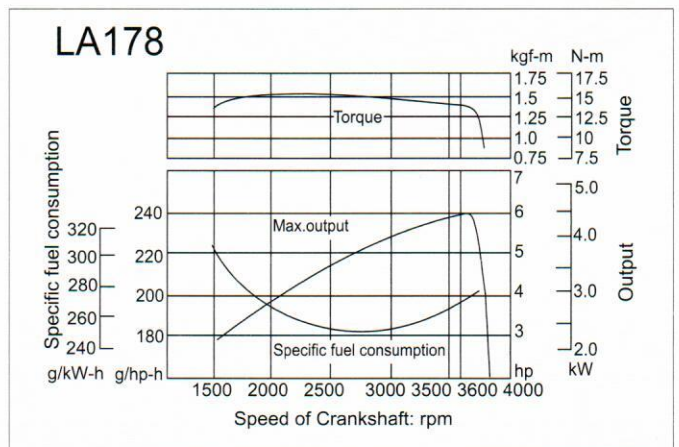

**MAC-TECH ENGINEERING SDN. BHD.** (156877-M)  
 21 & 23, Jalan 3/118C, Desa Tun Razak Industrial Park,  
 Cheras, 56000 Kuala Lumpur, West Malaysia.  
 Tel: (6) 03-91732606 (Hunting Line), 91732601, 91732602, 91732603  
 Fax: (6) 03-91732755, 91732893  
 Email: enquiry@mac-tech.com.my ■ http://www.mac-tech.com.my

