

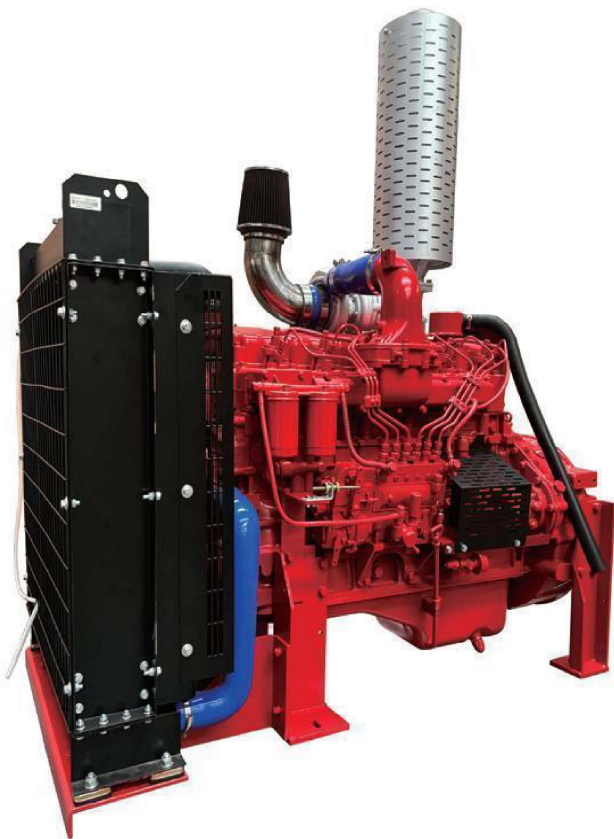

MAC-TECH DIESEL ENGINE

MD6132



Specification

Engine Model		MD6132
Type		Vertical, water-cooling, 4-stroke, direct-injector
Aspiration		Turbocharged
Number of Cylinders		6
Bore×Stroke (mm)		110x125
Compression Ratio		17.5:1
Total Displacement (L)		7.12
Rated Power	KW/HP	132/180
Rated Speed	r/min	2920
Fuel Consumption	g/kW.h	≤254
Rotating Direction at Output End		Counter-clockwise
Lubrication Oil		CF-4
Lubrication Oil Content	L	14
Lubrication Method		Pressure and splash
Starting Method		Electric
PTO Type		Option: 1. Shaft 2. Coupling 3. Drive Plate
Net Mass	kg	875

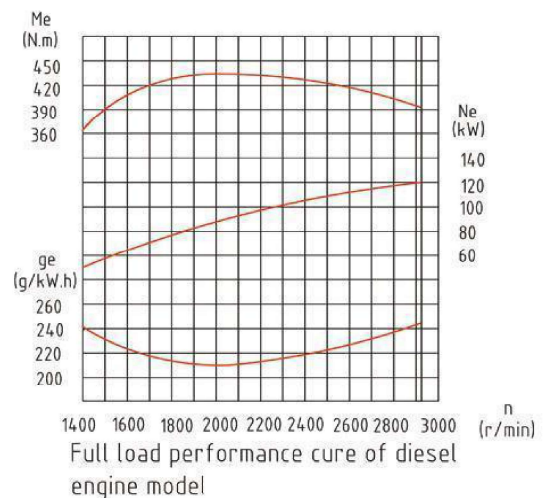
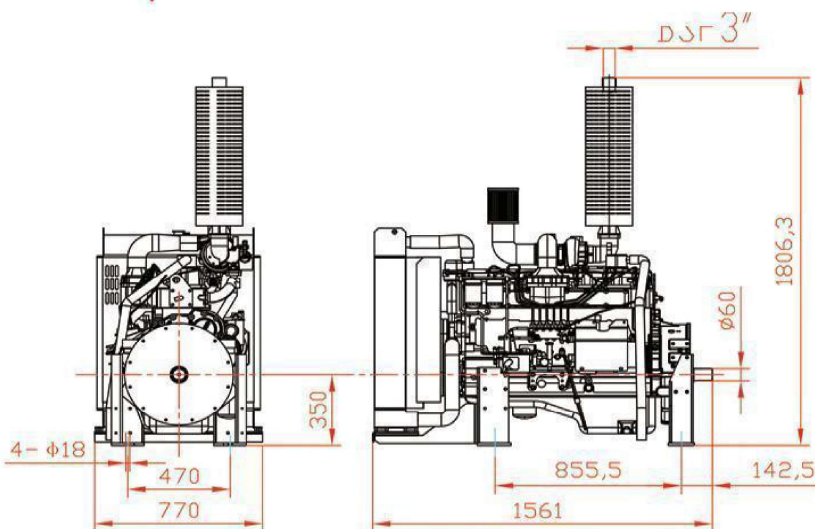

MAC-TECH ENGINEERING SDN. BHD. (156877-M)

21 & 23, Jalan 3/118C, Desa Tun Razak Industrial Park,
Cheras, 56000 Kuala Lumpur, West Malaysia.
Tel: (6) 03-91732606 (Hunting Line), 91732601, 91732602, 91732603
Fax: (6) 03-91732755, 91732893
Email: enquiry@mac-tech.com.my ■ <http://www.mac-tech.com.my>



MAC-TECH DIESEL ENGINE